

# Original BMW Accessories.

## Installation Instructions.



### Performance Steering Wheel Retrofit

**BMW 1 series (E81, E82, E87, E88)**

**BMW 3 Series (E90, E91, E92, E93)**

**These installation instructions are only valid for cars without SA 248 (steering wheel heating).**

**Retrofit kit No.**            32 30 0 443 170    Performance Steering Wheel Retrofit  
                                  32 30 0 445 258    Performance Steering Wheel Retrofit Kit

#### Installation time

The installation time is **about 1.5 hours**. This may vary depending on the condition of the car and the equipment in it.

#### Important information

These installation instructions are primarily designed for use within the BMW dealership organisation and by authorised BMW service companies.

In any event, the target group for these installation instructions is specialist personnel trained on BMW cars with the appropriate specialist knowledge.

All work must be completed using the latest BMW repair manuals, circuit diagrams, servicing manuals and work instructions in a rational order using the prescribed tools (special tools) and observing current health and safety regulations.

**In the event of any installation or function problems, restrict the troubleshooting session to about 0.5 hours for mechanical work or 1 hour for electrical work.**

In order to reduce costs and avoid any additional expense, send a query immediately to the Technical Parts Support via the Aftersales Assistance Portal (ASAP).

Specify the following information:

- Chassis number
- Part number of the retrofit kit
- A precise description of the problem
- Work steps already carried out

Do not archive the hard copy of these installation instructions since daily updates are made by ASAP!

#### Pictograms



Denotes instructions that draw your attention to dangers.



Denotes instructions that draw your attention to special features.



Denotes the end of the instruction or other text.

**Installation information**

Ensure that the cables and/or lines are not kinked or damaged as you install them in the car. The costs thereby incurred will not be reimbursed by BMW AG.

Additional cables/lines that you install must be secured with cable ties.

If the specified PIN chambers are occupied, bridges, double crimps or twin-lead terminals must be used.

All pictures show LHD cars; proceed accordingly on RHD cars.

On completion of the installation work, an initial setting must be performed on the performance steering wheel.

**Special tools required**

00 9 317 Trim wedge

## Table of contents

Section	Page
1. Parts list .....	4
2. Preparatory work .....	5
3. Connection diagram .....	6
4. Installation and cabling diagram .....	7
5. Installing the retrofit kit .....	8
6. Concluding work, coding and initial setting .....	10
7. Circuit diagram .....	11

## 1. Parts list

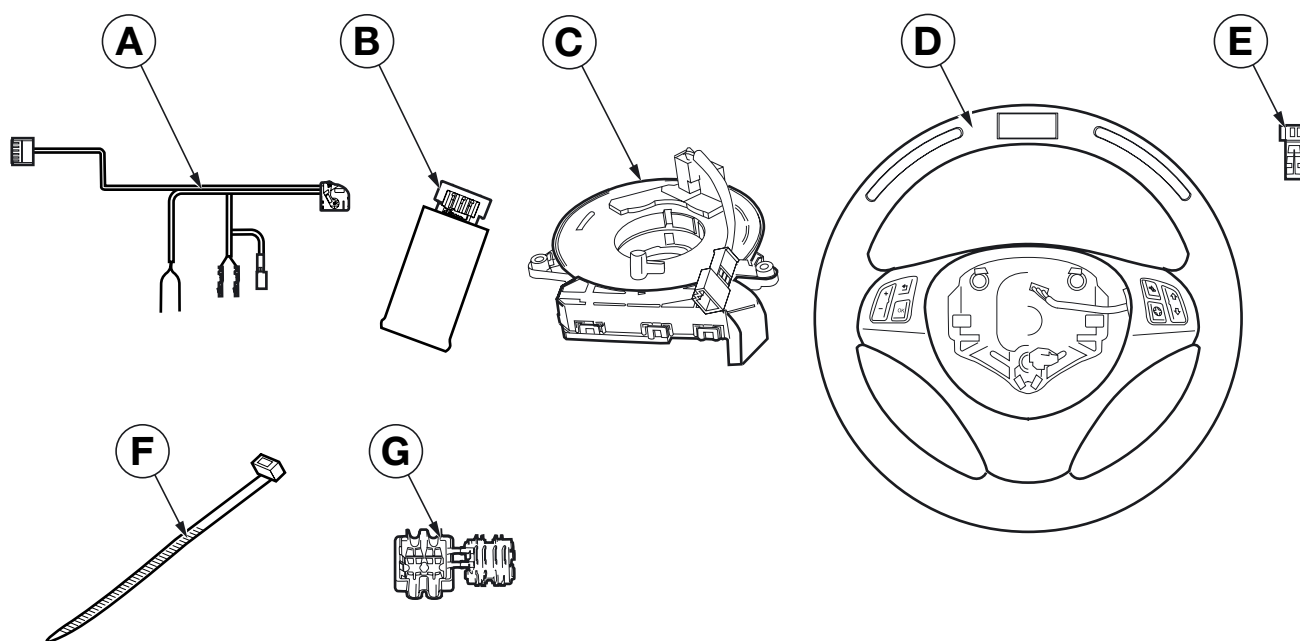

090 1321 Z

### Legend

- A** Retrofit cable
- B** Control module
- C** Coil spring cartridge
- D** Performance steering wheel (with trim)
- E** 2-pin socket casing SW
- F** Cable tie (x 15)
- G** Miniature connector (2x)

## 2. Preparatory work

	<b>TIS no.</b>
Conduct a brief test	---
Disconnect negative pole of battery	12 00 ...
<b>The following components must be removed first of all</b>	
Trim at the bottom right of the door pillar	51 43 150
Trim at the bottom right of the dashboard	51 45 181
Pedal trim	51 45 185
Bottom section of steering column trim	32 31 020
Top section of steering column trim	32 31 003
Steering wheel	32 33 ...
Coil spring cartridge	61 31 011

### 3. Connection diagram

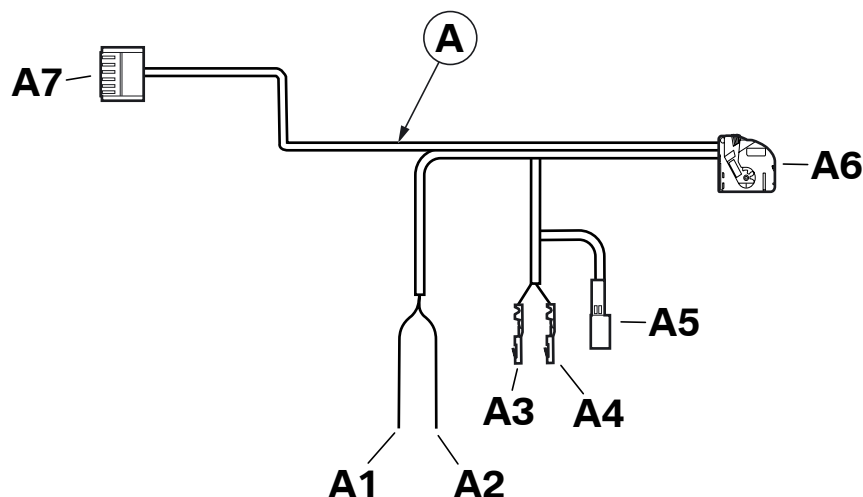

090 1323 Z

#### Legend

Item	Designation	Signal	Cable colour / Cross-section	Connection location in the car	Abbreviation / Slot
A	Retrofit cable	---	---	---	---
A1	Cable open	Terminal 15	GN/BR 0.5 mm <sup>2</sup>	With miniature connector <b>G</b> To the cable of the OBD socket in the driver's footwell	X19527 PIN 1
A2	Cable open	Terminal 31	BR 0.5 mm <sup>2</sup>	With miniature connector <b>G</b> To the cable of the OBD socket in the driver's footwell	X19527 PIN 4
A3	Socket contact	PT-Can High	BL/RT 0.35 mm <sup>2</sup>	To junction box behind glove box	X14271 PIN 1
A4	Socket contact	PT-Can Low	RT 0.35 mm <sup>2</sup>	To junction box behind glove box	X14271 PIN 2
A5	2-pin plug casing SW	---	---	With socket casing <b>E</b> to disconnected cable from connector <b>X14271</b>	---
A6	12-pin socket casing SW	---	---	To control unit <b>B</b>	---
A7	12-pin socket casing WS	---	---	To coil spring cartridge <b>C</b>	X10170

## 4. Installation and cabling diagram

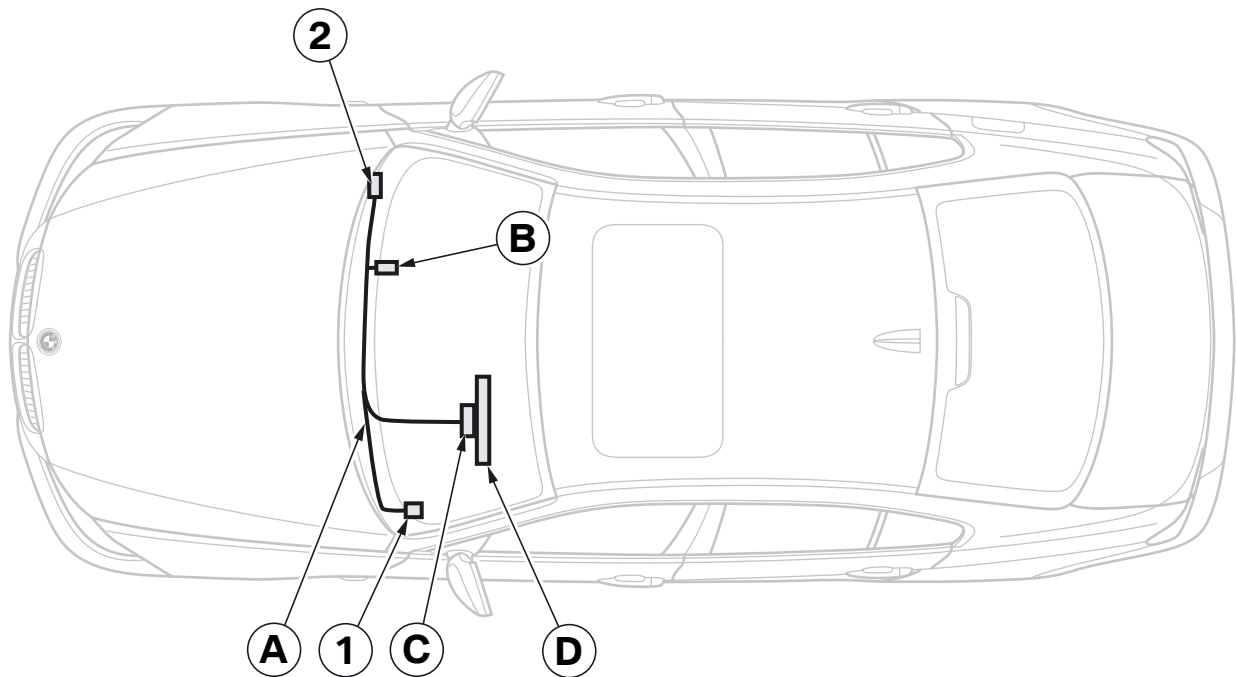

090 1320 Z

### Legend

- A** Retrofit cable
- B** Control module
- C** Coil spring cartridge
- D** Performance Steering Wheel
  
- 1** OBD socket
- 2** Junction box on passenger side

## 5. Installing the retrofit kit

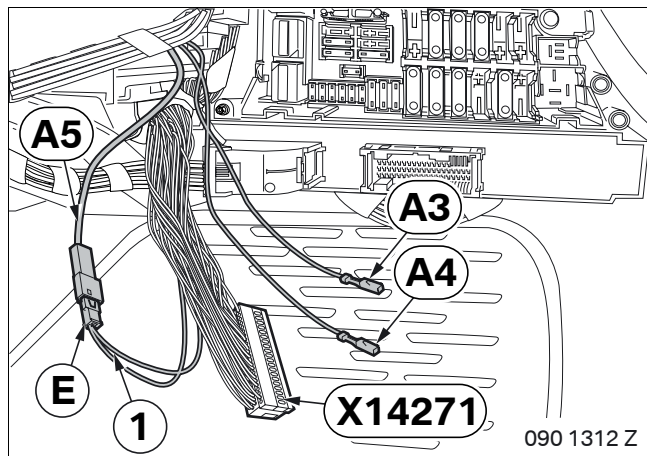

Route branches **A3–A5** to the junction box.

Disconnect cable (1) from PIN 1 and PIN 2 of plug **X14271**, 54-pin SW and connect to following pins in socket casing **E**:

- BL/RT cable from Pin 1 to Pin 1
- RT cable from PIN 2 to Pin 2

Connect branches **A3** and **A4** to plug **X14271** as follows:

- Branch **A3**, BL/RT cable, to PIN 1
- Branch **A4**, RT cable, to PIN 2

Connect branch **A5** to socket casing **E**.

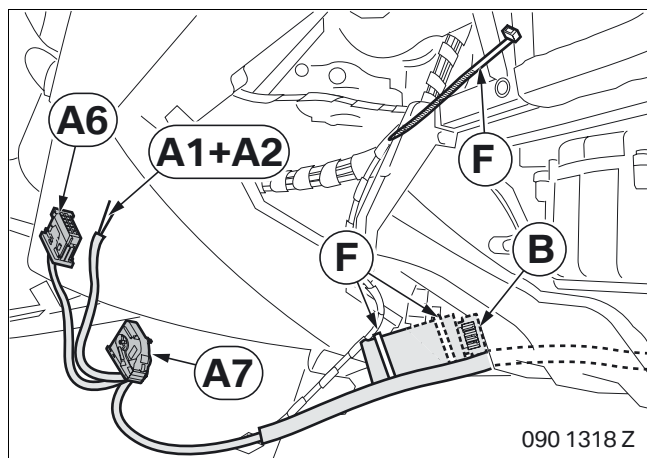

Connect branch **A6** (12-pin SW socket casing) to the control module **B**.

Attach control unit **B** to the standard wiring harness using cable ties **F**.

Route branch **A1+A2** to the OBD socket and branch **A7** to the steering column.

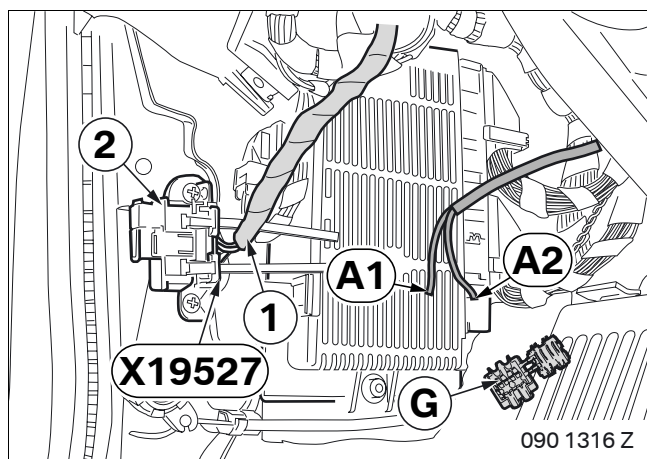

Remove about 100 mm of the winding (1) from the cable to the OBD socket (2).

Connect branch **A1**, GN/BR cable, using mini-connectors **G** to the same colour cable from PIN 1 of plug **X19527**.

Connect branch **A2**, BR cable, using mini-connectors **G** to the same colour cable from PIN 4 of plug **X19527**.

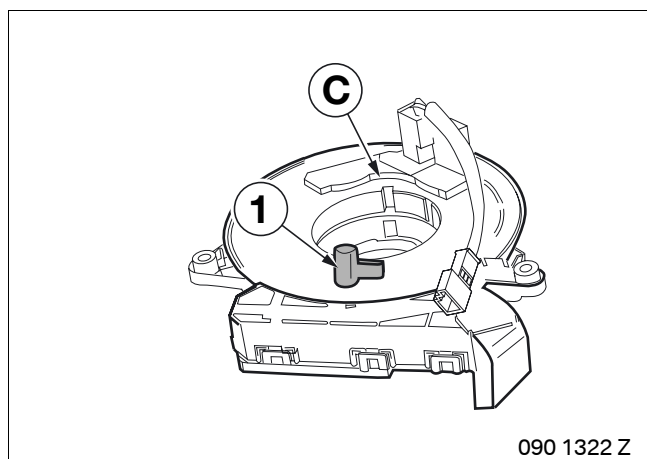

Remove transportation lock (1) from coil spring cartridge **C**.

Install coil spring cartridge **C** in car in accordance with TIS-RA: 61 31 011.



## 5. Installing the retrofit kit

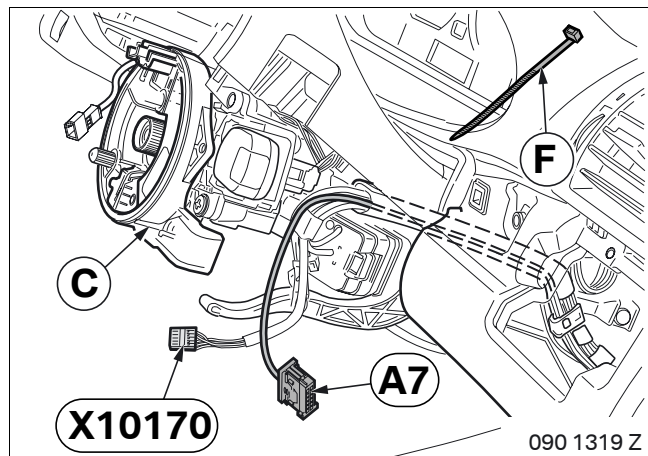

Disconnect all cables from plug **X10170** and connect to branch **A7** as follows:

- BR cable from PIN 1 to PIN 1
- BR/GE cable from PIN 2 to PIN 2
- GE/BR cable from PIN 3 to PIN 3
- GE/SW cable from PIN 4 to PIN 4
- GR/BR cable from PIN 5 to PIN 5
- GR/SW cable from PIN 6 to PIN 6

Connect branch **A7** to the coil spring cartridge **C**.

Secure retrofit cable with cable ties **F** to existing cable harnesses.

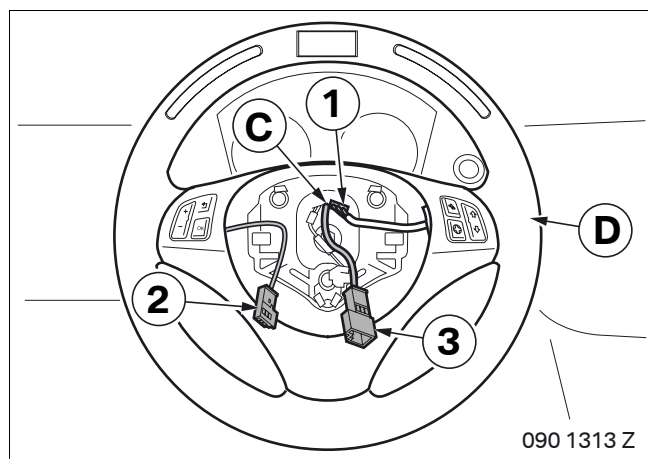

Connect the plug (1) to coil spring cartridge **C**.

Connect 3-pin SW socket casing (2) of the performance steering wheel **D** to 3-pin SW pin casing (3) of the coil spring cartridge **C**.

 Refer to the safety instructions for handling the airbag. ◀

Install the centre console as described in TIS RA 32 33.

## 6. Concluding work, coding and initial setting

This retrofit system does not require coding.

- Connect the battery
- Conduct a brief test
- Conduct a function test
- Re-fit the car components as required
- Making basic settings

### Basic settings

To ensure the unit functions properly, two basic settings must be performed on completion of the installation:

- Simultaneously hold down the left (**L**) and right (**R**) keys on the performance steering wheel while switching on the ignition
- Using the key **R**, select either diesel or petrol-engined car (the small box around the text signifies that the option is selected)
- Press the key **L** to save the setting and to advance to the setting "Correction factor for speed"
- Start the engine and maintain a constant, easily readable engine speed (e.g. 1000 rpm)
- Compare the display on the steering wheel with that on the rev counter
- You can increase the correction factor by holding the key **R** down, or reduce it by tapping the key **R** briefly several times until the two displays correspond
- When you switch the ignition off again, the settings are stored

## 7. Circuit diagram

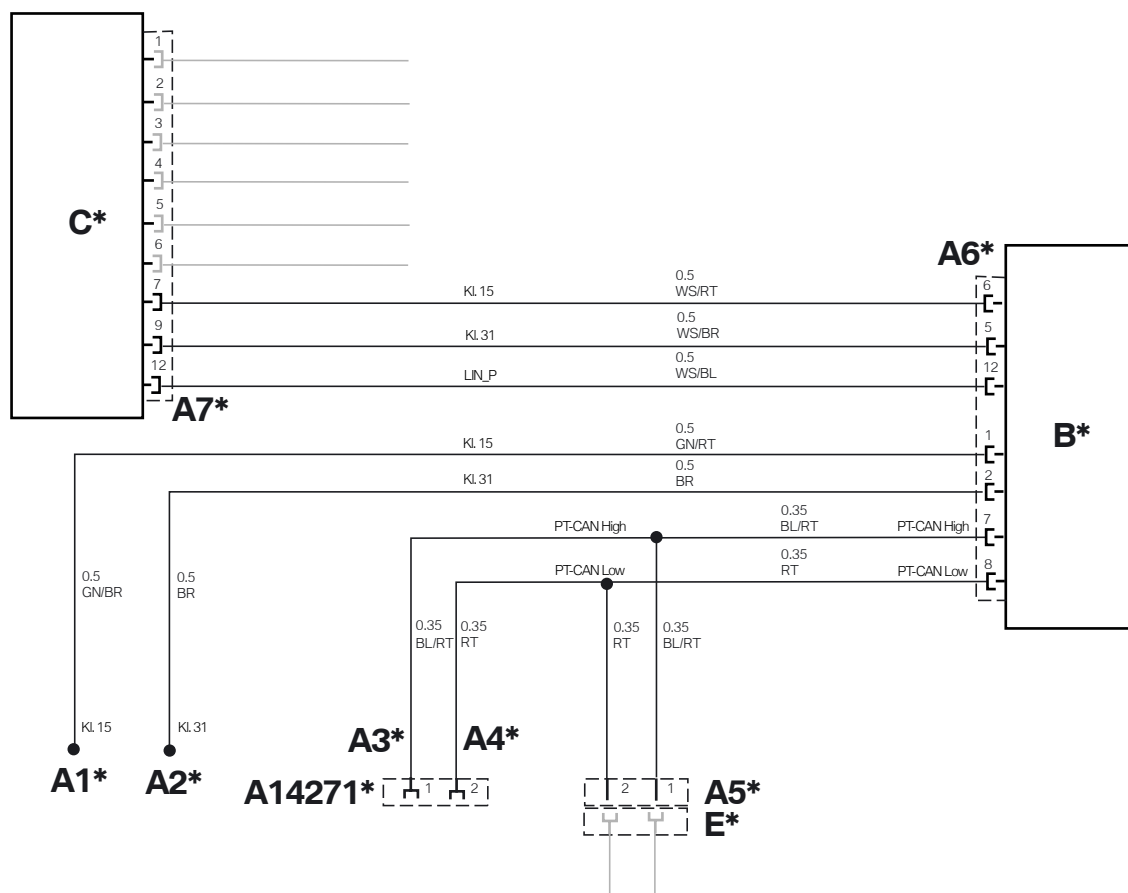

090 1311 Z

### Legend

- A1\*** Line open, with mini connector to plug **X19527**, PIN 1
- A2\*** Line open, with mini connector to plug **X19527**, PIN 4
- A3\*** Socket contact to junction box SW 54-pin plug **X14271**
- A4\*** Socket contact to junction box SW 54-pin plug **X14271**
- A5\*** SW 2-pin casing to socket casing **E\***
- A6\*** SW 12-pin socket casing on control module **B\***
- A7\*** WS 12-pin casing to coil spring cartridge **C\*/X10170**

All the designations marked with an asterisk (\*) apply only to these installation instructions or this circuit diagram.

### Cable colors

BL	Blue
BR	Brown
Green	Green
GR	Grey
RT	Red
SW	Black
WS	White